

STAINLESS STEEL CURVED BLADE REGISTERS AND GRILLES

304 (Standard) or 316 (Optional) Stainless - Satin Finish

22 GA. Frame, 24 GA. Blades
Maximum single section is 72" x 72". Sizes over 30" in blade direction have interior mullions.
See reverse side for butting details on multiple piece grilles.

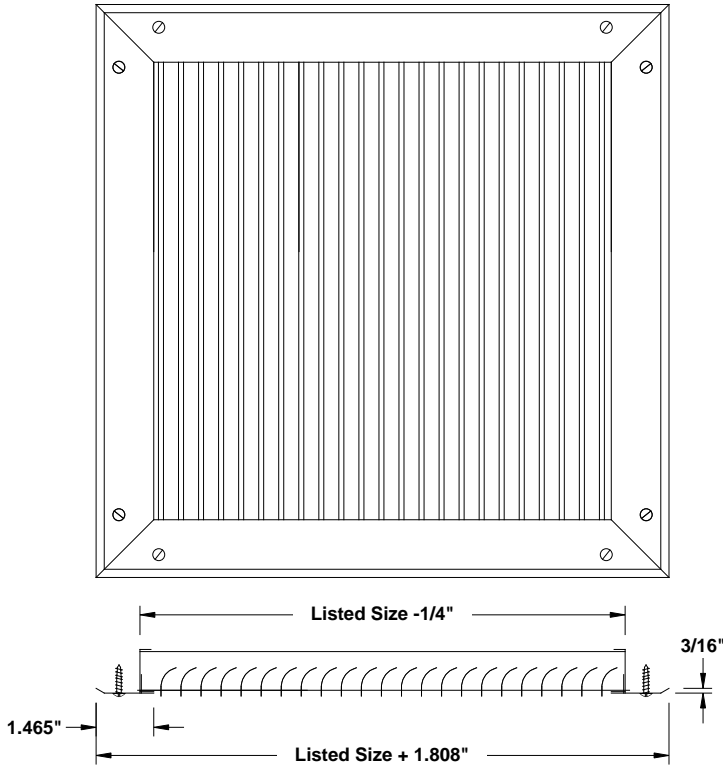

THROW PATTERNS

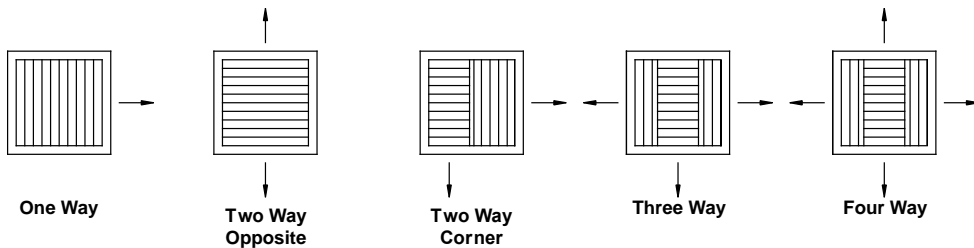

ACCESSORIES

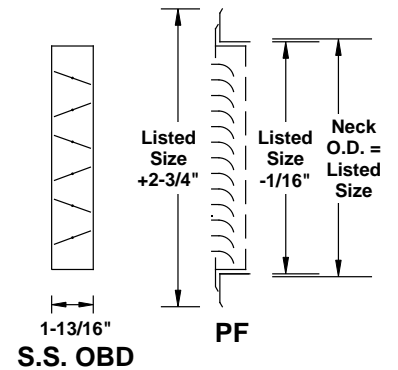

Quantity	W	H	Throw Pattern	Type S.S.		Accessories	Tag
				304	316		

To maintain KEES' policy of continuous product development, we reserve the right to change prices, specifications, ratings and dimensions without notice or obligation.

Project				Location			
Engineer							
Architect			Dwg. No.	SD-SSCU			
Contractor			Date	12/15			



KEES INCORPORATED
400 S. Industrial Dr.
Elkhart Lake, WI 53020
Phone: (920) 876-3391
Fax: (920) 876-3065
Website: www.kees.com

STAINLESS STEEL CURVED BLADE REGISTERS AND GRILLES

304 (Standard) or 316 (Optional) Stainless - Satin Finish

22 GA. Frame, 24 GA. Blades

Maximum single section is 72" x 72". Sizes over 30" in blade direction have interior mullions.
 Sizes exceeding maximum single section will be made in multiple individual sections to fit opening size.
 Mullion supports within opening to be provided by others.

MULTIPLE SECTION BUTTING DETAIL

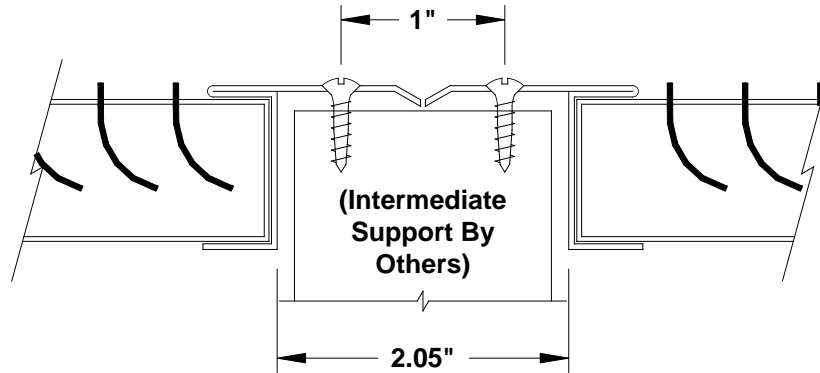

To maintain KEES' policy of continuous product development, we reserve the right to change prices, specifications, ratings and dimensions without notice or obligation.

Project		Location	
Engineer			
Architect		Dwg. No.	SD-SSCU
Contractor		Date	12/15



KEES INCORPORATED
 400 S. Industrial Dr.
 Elkhart Lake, WI 53020
 Phone: (920) 876-3391
 Fax: (920) 876-3065
 Website: www.kees.com